

ESP32 LED Pixel (WS2812) Driver Board - MLP201172

Features and Benefits

- 5V or 12V Operation
- Works With ESP32 Wemos D1 Wi-Fi Board
- On-board 5V Regulator powers the Wemos D1
- 4 Data Outputs
- Reverse Polarity Protection
- 5V data output to LED pixels
- Screw terminal connections
- Analogue audio input option

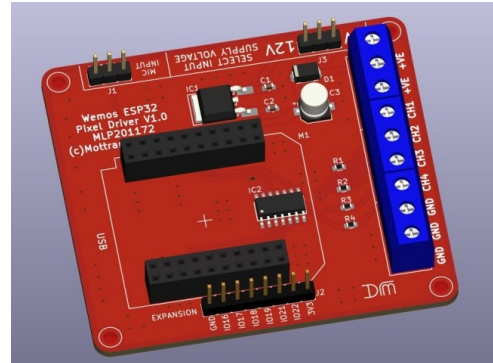

Product Details

The MLP201172 provides a simple solution for connecting WS2812 or similar LED pixel strips to the popular Wemos D1 Mini ESP32 Wi-Fi module. An on-board 74HCT125 line driver provides a 5V P/P output from the normal 3.3V output supplied by the ESP32 chip as used on the D1 Mini.

The board provides reverse polarity protection for the PCB only, care should be taken to protect the LED strip. The board can be used with either 5V or 12V LED strips when using the appropriate power supply. There is an option link on the board (J3) to select between a 5V or 12V supply, it's important to select this link for the supply used or the Wemos D1 Mini will be damaged. Please note the boards 5V regulator powers the Wemos D1 Mini and 74HCT125 only, it does not power the LED output.

A Sound reactive option is possible via a 3 pin header for use with an external analogue microphone board, the microphone is then connected to the Wemos D1 Mini's analogue input.

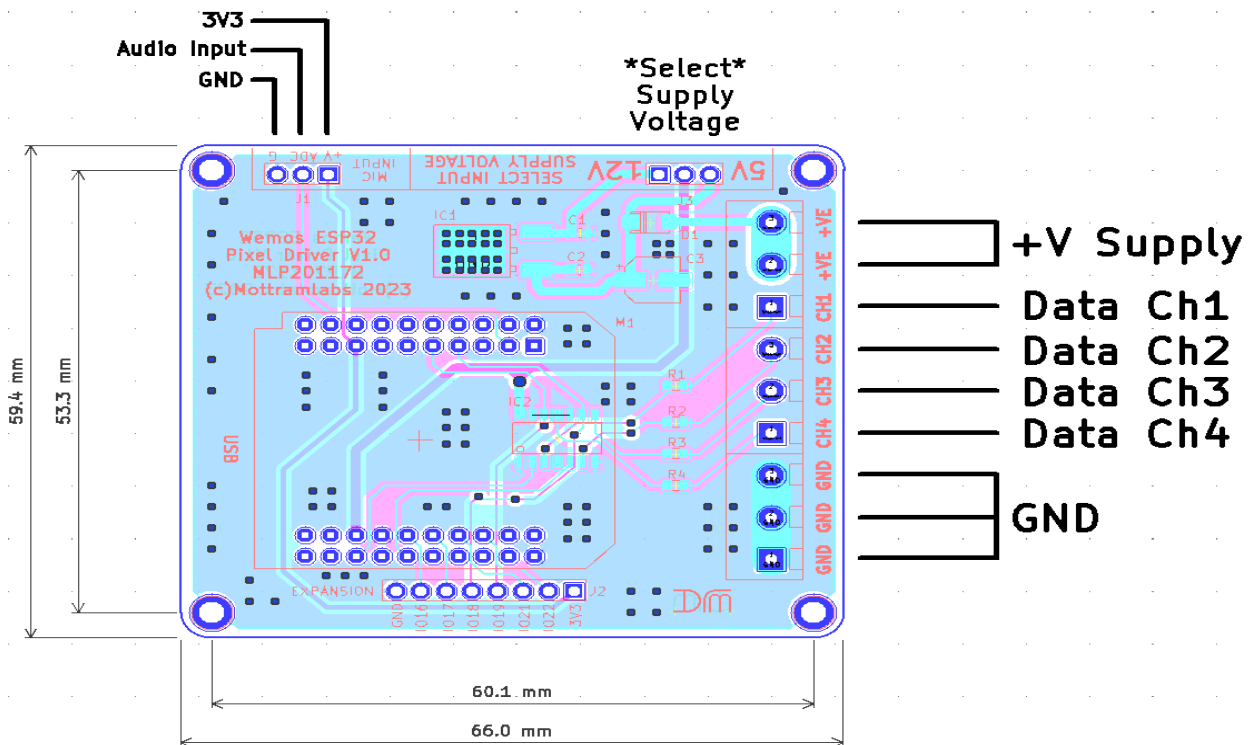

J3 Link

The voltage selection must match the input supply, so for 5V this link must be set to 5V and for 12V select 12V. Failure to do this will damage the PCB and any Wemos D1 plugged in.

MLP201172 - Schematic

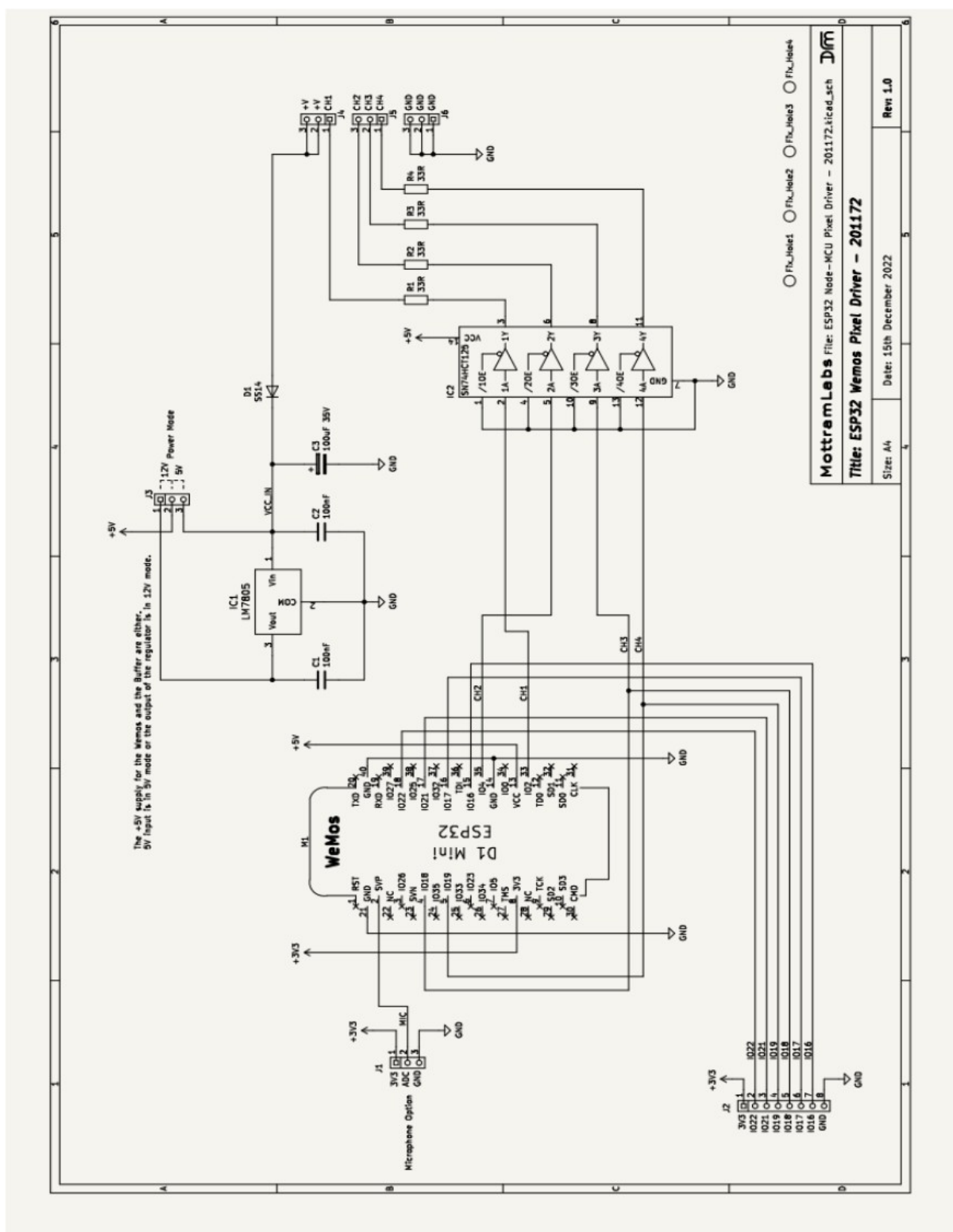

Software – WLED

Although the board can work with a range of software one of the most popular and feature rich is WLED. Below are some links to the WLED project page and a fork “WLED Sound Reactive”. This version adds as the name suggests sound reactive modes, this version requires an external audio input. The simplest way is to add a microphone board to the Wemos D1 Mini’s analogue input.

Flashing Tool

ESPHome-Flasher is a python utility for programming the Wemos D1 Mini

<https://github.com/esphome/ESPHome-Flasher>

WLED

WLED Github Page

<https://github.com/Aircoookie/WLED>

WLED Releases

<https://github.com/Aircoookie/WLED/releases>

WLED Web Installer Tool

<https://install.wled.me/>

Sound Reactive WLED

Sound Reactive WLED Releases

<https://github.com/atuline/WLED/releases>

Sound Reactive Wiki

<https://github.com/atuline/WLED/wiki>

Audio connection Options

<https://github.com/atuline/WLED/wiki/Analog-Audio-Input-Options>
